



City of Norman
Visitability Program Q and A

DEVELOPMENT SERVICES DIVISION
Building Permits and Inspections
201-A W. Gray St. Norman OK 73069
Permits: (405) 366-5339

The below question and answers are regarding the City of Norman's Pilot Visitability Program.

Question: What is a Visitable Dwelling?

Answer: A Visitable Dwelling is a home that has features that allow mobility impaired and aging in place individuals to live in or visit with fewer constraints than most dwellings.

Question: What is the City of Norman's Visitable Resolution?

Answer: On 6/22/2021 City Council approved resolution R-2021-118 to create a Pilot Program that begins on 8/1/2021 and runs through 7/31/2023 to create an incentive based program encouraging builders to construct Visitable Dwellings.

Question: What projects are eligible to enroll in the program?

Answer: New One and Two Family Dwellings and Townhouses with less than four dwelling units.

Question: What kind of incentive can a builder get if they complete the program?

Answer: A home that completes the program will not have to pay their building permit fee which is .14 cents per square foot of project area (all areas under the roof). A 2000 square foot home with a 400 square foot garage and a 200 square foot patio would be eligible to receive a credit of \$364 (2600 x .14).

Question: What do I have to do to enroll in the program?

Answer: At the time of submitting for a building permit you should complete the Visitability Program Participation Application. It can be found **HERE**.

Question: When I submit my enrollment is there anything else I need to do or provide?

Answer: Yes, your floor plans demonstrating compliance with a Visitable dwelling should be submitted and further your Norman Utilities Accounts must be in good standing.

Question: What information needs to be on the floor plans to demonstrate a dwelling will meet the Visitability Code?

Answer: Pertinent details of a visitable dwelling that should be on your plans: no step entry, threshold detail, doors of minimum dimensions, pathways/halls/bottlenecks exceed minimum widths, a bathroom, living room, kitchen all accessed by a Visitable pathway, clear space at the water closet in the visitable bathroom.

Question: I enrolled in the Visitable Program what happens next?

Answers: Your building permit fee will not be charged to you and a building permit will be issued (all other fees must be paid). At this point you will proceed in building and completing the home. Before advancing to Certificate of Occupancy (CO), you must request a Visitable Final Inspection.

Question: When and how do I request the Visitable Final Inspection?

Answer: You will be able to request this inspection after all the trade finals are approved, and all construction is complete – move in ready. For coordination purposes best practice will be to request the Visitable Final at the time of the Building Final. You can request the inspection via our online system at www.normanok.gov or by phone through a Permit Technician.

Answer: I failed my visitable final Inspection what happens now?

There are two options - make the corrections and recall the inspection or withdraw from the program which will require payment of the building permit fee.

Question: Can I get a Certificate of Occupancy (CO) or Temporary Certificate of Occupancy (TCO) before I get my visitable Final Inspection?

Answer: You can get a CO or TCO without an approved Visitable Final Inspection but you will have to withdraw from the program and repay your building permit fee.

What changes to my home are required to make it a Visitable home?

See attached Exert from the ICC A117.1-2009 regarding Type C Visitable Units with added drawing and staff explanations. Key components include:

Where can I find the Visitability Code and ICC A117.1-2009?

https://codes.iccsafe.org/content/icca117-12009/chapter-10-dwelling-units-and-sleeping-units#ICCA117.12009_Ch10_Sec1005

Attachment: Exert from ICC A117.1-2009 with staff explanations in red

Accessible and usable Buildings and Facilities ICC A117.1-2009

Complete Code can be seen at: <https://codes.iccsafe.org/content/icca117-12009>

1005 Type C (Visitable) Units

1005.1 General. Type C (Visitable) dwelling units shall comply with Section 1005.

1005.2 Unit Entrance. At least one-unit entrance shall be on a circulation path complying with Section 1005.5 from a public street or sidewalk, a dwelling unit driveway, or a garage.

1005.3 Connected Spaces. A circulation path complying with Section 1005.5 shall connect the unit entrance complying with Section 1005.2 and with the spaces specified in Section 1005.4.

1005.4 Interior Spaces. The entrance level shall include a toilet room or bathroom complying with Section 1005.6 and one habitable space with an area 70 square feet (6.5 m²) minimum. Where a food preparation area is provided on the entrance level, it shall comply with Section 1005.7.

Exception: A toilet room or bathroom shall not be required on an entrance level with less than 120 square feet (11.1 m²) of habitable space.

1005.5 Circulation Path. Circulation paths shall comply with Section 1005.5.

1005.5.1 Components. The circulation path shall consist of one or more of the following elements: walking surfaces with a slope not steeper than 1:20, doors and doorways, ramps, elevators complying with Sections 407 through 409, and wheelchair (platform) lifts complying with Section 410.

1005.5.2 Walking Surfaces. Walking surfaces with slopes not steeper than 1:20 shall comply with Section 303. *(Section 303 states vertical changes in level restricted to ¼", with ½" elevation change allowed if the surface has a beveled surface at a 1:2 slope)*

1005.5.2.1 Clear Width. The clear width of the circulation path shall comply with Section 403.5. *(Per 403.5 typically 36" wide minimum)*

1005.5.3 Doors and Doorways. Doors and doorways shall comply with Section 1005.5.3

1005.5.3.1 Clear Width. Doorways shall have a clear opening of 31 3/4 inches (805 mm) minimum. Clear opening of swinging doors shall be measured between the face of the door and stop, with the door open 90 degrees.

1005.5.3.2 Thresholds. Thresholds shall comply with Section 303. *(Changes in level restricted to 1/4", with 1/2" elevation change allowed if the surface has a beveled surface at a 1:2 slope. See detail.)*

Exception: Thresholds at exterior sliding doors shall be permitted to be 3/4 inch (19 mm) maximum in height, provided they are beveled with a slope not steeper than 1:2.

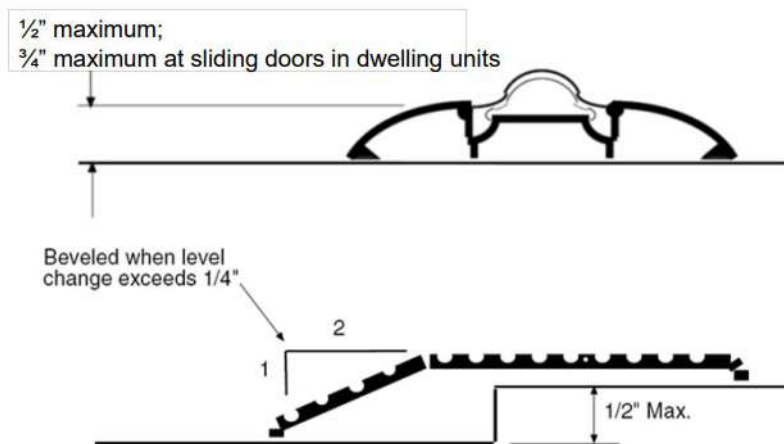

1005.5.4 Ramps. Ramps shall comply with Section 405. *(A ramp is a surface with a slope greater than 1:20 with a maximum slope of 1:12, it must be 36" wide minimum, must have a landing at the top and bottom and requires handrails on both sides of the ramp if there is 6" of vertical travel)*

Exception: Handrails, intermediate landings and edge protection are not required where the sides of ramp runs have a vertical drop off of 1/2 inch (13 mm) maximum within 10 inches (255 mm) horizontally of the ramp run.

1005.5.4.1 Clear Width. The clear width of the circulation path shall comply with Section 403.5. *(Per 403.5 typically 36" wide minimum)*

1005.6 Toilet Room or Bathroom. At a minimum, the toilet room or bathroom required by Section 1005.4 shall include a lavatory and a water closet. Reinforcement shall be provided for the future installation of grab bars at water closets. Clearances at the water closet shall comply with Section 1004.11.3.1.2. *(Reinforcement for Grab bars is required at the water closet. See Figures 604.5.1 and 604.5.2 for locations to install them. Clearances at water closets to comply with a Type B Dwelling See drawings from Figure 1004.11.3.1.2.)*

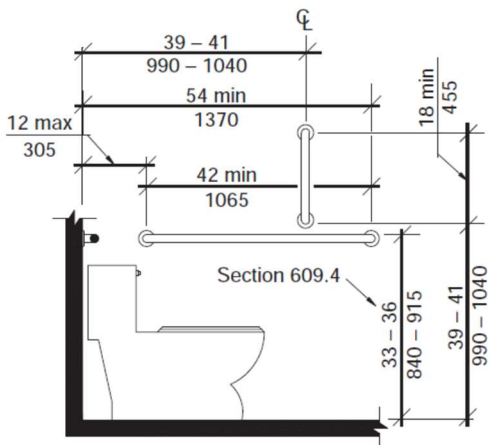

Note: For children's dimensions see Fig. 609.4.2

**FIG. 604.5.1
SIDE WALL GRAB BAR FOR WATER CLOSET**

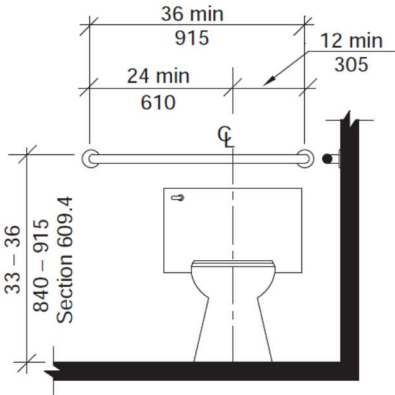

Note: For children's dimensions see Fig. 609.4.2

**FIG. 604.5.2
REAR WALL GRAB BAR FOR WATER CLOSET**

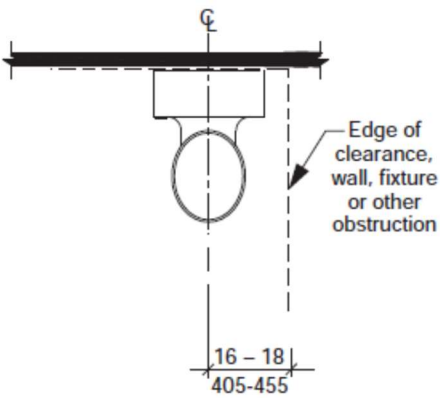

(a) Water closet location

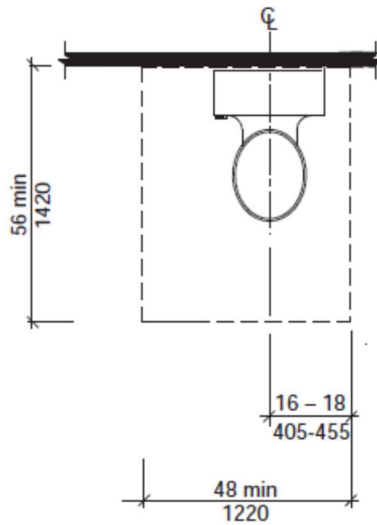

(b) Clearance width and depth

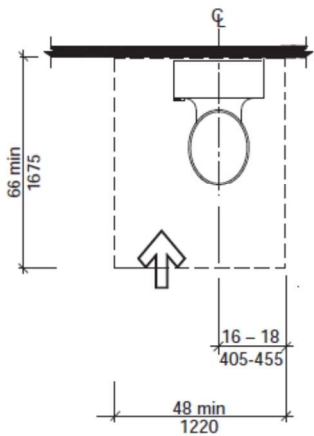

**(c) Increased clearance depth -
forward approach**

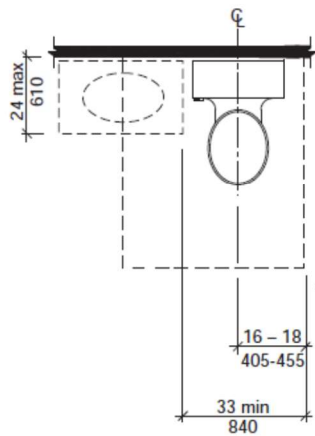

(d) Clearance with lavatory overlap

**FIG. 1004.11.3.1.2
CLEARANCE AT WATER CLOSETS IN TYPE B UNITS**

1005.7 Food Preparation Area. At a minimum, the food preparation area shall include a sink, a cooking appliance, and a refrigerator. Clearances between all opposing base cabinets, counter tops, appliances or walls within the food preparation area shall be 40 inches (1015 mm) minimum in width.

Exception: Spaces that do not provide a cooktop or conventional range shall be permitted to provide a clearance of 36 inches (915 mm) minimum in width.

1005.8 Lighting Controls and Receptacle Outlets.

Receptacle outlets and operable parts of lighting controls shall be located 15 inches (380 mm) minimum and 48 inches (1220 mm) maximum above the floor.

Exception: The following shall not be required to comply with Section 1005.8.

1. Receptacle outlets serving a dedicated use.
2. Controls mounted on ceiling fans and ceiling lights.
3. Floor receptacle outlets.
4. Lighting controls and receptacle outlets over countertops.