

**HISTORIC DISTRICT COMMISSION  
MINUTES OF**

**December 5, 2011**

The Historic District Commission of the City of Norman, Cleveland County, State of Oklahoma, met for the Regular Meeting on December 5, 2011, at 7:00 p.m. Notice and Agenda of the meeting were posted at 201 West Gray Building A, the Norman Municipal Building and at [www.normanok.gov](http://www.normanok.gov) twenty-four hours prior to the beginning of the meeting.

Co-Chair A Starr called the meeting to order at 7:05 p.m.

**Item No. 1, being: Roll Call.**

MEMBERS PRESENT:                   Rangar Cline  
  Anna Eddings  
  David John  
  Chesley Potts\*  
  Anaïs Starr  
  Scott Williams\*\*

MEMBERS ABSENT:                   Julie Benningfield  
  Neil Robinson

STAFF MEMBERS PRESENT:        Susan Atkinson, Historic Preservation Officer  
  Jolana McCart, Admin Tech IV

GUESTS PRESENT:                   Judy Robinson  
  Mike Brinkley  
  Kent VonBargen

**Item No. 2, being: Approval of the Agenda.**

**Motion** by R Cline for approval; **Second** by R Kaplan. All approve.

≈      ≈      ≈      ≈      ≈      ≈

**Item No. 3, being: Approval of Minutes from the November 7, 2011 Regular Meeting.**

**Motion** by A Eddings for approval; **Second** by R Cline. All approve.

≈ ≈ ≈ ≈ ≈ ≈

**Item No. 4, being: Staff report on projects approved by Administrative Bypass since November 7, 2011.**

Staff reported that there had been none issued.

≈ ≈ ≈ ≈ ≈ ≈

**Item No. 5, being: Staff report on CLG projects.**

S Atkinson reported that the window workshop was held on November 19<sup>th</sup> at 439 Chautauqua. 4 windows were stripped and reinstalled.

Swearingen Communications has completed the initial research/pre-production phase and four half-days of video production for this project.

\*C Potts arrived at 7:08

\*\* S Williams arrived at 7:10

≈ ≈ ≈ ≈ ≈ ≈

**Item No. 6, being: Election of Officers.**

**Nomination:** R Cline nominated N Robinson for Chair and A Starr for Co-Chair; **Second** by R Kaplin. All approve.

≈ ≈ ≈ ≈ ≈ ≈

**Item No. 7, being: Continuation of Certificate of Appropriateness at 642 S Lahoma. (Granted 10-3-11).**

The owners are searching for the right 15 light front door.

≈ ≈ ≈ ≈ ≈ ≈

**Item No. 8, being: Continuation of Certificate of Appropriateness at 439 Chautauqua.  
(Granted 11-7-11)**

The owner is in the process of getting a building permit.

≈ ≈ ≈ ≈ ≈ ≈

**Item No. 9, being: Request for Certificate of Appropriateness at 439 S Lahoma.  
(Granted 11-7-11 for 3 windows; 3 windows were denied).**

The applicant is appealing to City Council. This item will be presented at the December 13<sup>th</sup> meeting. The City Council meetings are held at 6:30 in the Municipal Building.

≈ ≈ ≈ ≈ ≈ ≈

**Item No. 10, being: Request for Certificate of Appropriateness at 639 S Lahoma.**

Staff presented the staff report; the applicant, Mike Brinkley, was present to answer questions.

This application was for several different requests, each being discussed individually. After this discussion, the Commission asked for complete drawings for the east elevation of the house and window designs/pictures.

**Motion** by S Williams to accept the application as presented with the following exceptions: staff approval of the window style and material. The east elevation request will need to come back to the Commission with completed drawings. **Second** by R Cline. All approve.

≈ ≈ ≈ ≈ ≈ ≈

**Item No. 11, being: Request for Certificate of Appropriateness at 635 S Lahoma.**

S Atkinson gave the staff report. Judy Robinson, applicant, was present to answer questions.

A discussion was held on the size and roof changes.

**Motion** by D John to approve application as presented. **Second** by R Cline. All approve.

≈ ≈ ≈ ≈ ≈ ≈

**Item No. 12, being: Miscellaneous.**

There was none.

≈ ≈ ≈ ≈ ≈ ≈

**Item No. 13, Adjournment. 8:55 p.m.**

Passed and approved this 9th day of January 2011.

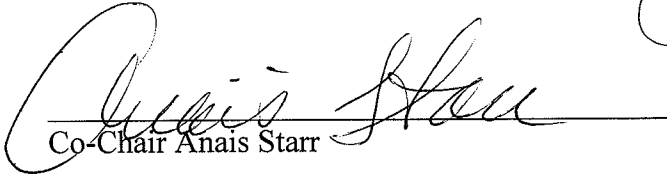
  
Co-Chair Anais Starr

**Susan Atkinson**

---

**From:** sheila.swearingen@gmail.com on behalf of Sheila Swearingen [sheila@swearingenvideo.com]

**Sent:** Monday, December 05, 2011 9:44 AM

**To:** Susan Atkinson

**Subject:** Brief update on Swearingen Communications Historic downtown Norman video progress

Swearingen Communications has completed the initial research/pre-production phase and the four half-days of video production for this project. During the production phase, we shot footage of the October Arts Walk in downtown Norman, events and signage at the Sooner Theatre, exteriors of historic buildings in the downtown Main Street district and interiors showing the work being done to rehabilitate and re-purpose these buildings. We taped interviews with nine individuals who talked about different aspects of the downtown historic district revitalization initiative, as business owners, developers, historic preservation professionals and interested residents of Norman.

Sheila Swearingen  
Swearingen Communications  
525 S. Main Street, Ste. 525  
Tulsa, OK 74103  
cell: 918-584-3509  
office: 918-556-3800  
[www.swearingenvideo.com](http://www.swearingenvideo.com)

[Home](#) · 
 [Casement Windows](#) · 
 [Mahogany Casements](#) · 
 [Architectural Windows](#) · 
 [Awning Windows](#) · 
 [Double Hung Windows](#) · 
 [Glass \(French\) Doors](#) · 
 [Complete Guide to Wood Windows](#)



## Double Hung Wood Windows

### FEATURES

- Our sash are tilt-in and removable for easy cleaning.
- Adjustable spring balance jamb liners.
- Primed wood exteriors are ready for paint or stain.
- 7/16" insulated glass manufactured to meet today's changing climates is standard.
- Your choice of white or bronze hardware and white or bronze screens.

### LIGHT CONFIGURATION OPTIONS

- Single Glazed true divided light doublehung wood windows with 1-1/4" or 7/8" muntin bars.
- 1" Insulated doublehung wood windows with simulated divided lights
- 1" Insulated doublehung wood windows with white or bronze grills between the glass.
- Insulated doublehung wood windows with true divided lights with 1-1/4" muntin bars.

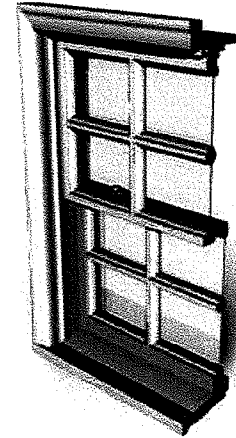

### OTHER OPTIONS

- Grey or bronze tint, obscure, or tempered glass.
- Historic putty glazed.
- Applied jamb extensions up to 7-1/2".
- Wood or aluminum screens.

### SIZE CHARTS

- [Single Units to 6'10" in height](#)
- [Single Units 7'6" to 8'4" in height](#)
- [Double Units](#)
- [Triple Units](#)
- [Picture Windows](#)

### DETAIL DRAWINGS

- [Sash Detail](#)
- [Section Details](#)  
(Stucco Wall Installation, Wood Siding Installation, Masonry Wall Installation)



## Buy Factory Direct!

Avalon Windows & Doors · P.O. Box 12071 · Spring, Texas 77391  
 Phone: 713-691-4600 · Toll Free: 800-222-4142 · Fax: 281-251-9485

Send us [email](#) or Use our convenient [Information Request Form](#)

# Double Hung Windows

Double Hung Windows

## FEATURES

- All sash are tilt-in and removable for easy cleaning

- Adjustable spring balance jamb liners

Primed wood exteriors ready for paint or stain

- Standard 7/16 insulated glass manufactured to meet today's changing climates

- White or bronze hardware

- White or bronze screens available

## OPTIONS

- Applied jamb extensions up to 7-1/2"

- White or bronze grills between glass

- Single glazed true divided lights with historical 1-1/4" or 7/8" Mutin bars

- Insulated true divided lights

- Grey or bronze tint, obscure, or tempered glass

- Wood screens available

- Historic putty glazed

- Insulated simulated divided lights

DHCT-18	DHCT-20	DHCT-24	DHCT-28	DHCT-30	DHCT-34	DHCT-38
DHTR-18	DHTR-20	DHTR-24	DHTR-28	DHTR-30	DHTR-34	DHTR-38
DH18210	DH20210	DH24210	DH28210	DH30210	DH34210	DH38210
DH1832	DH2032	DH2432	DH2832	DH3032	DH3432	DH3832
DH18310	DH20310	DH24310	DH28310	DH30310	DH34310	DH38310
DH1842	DH2042	DH2442	DH2842	DH3042	DH3442	DH3842
DH1846	DH2046	DH24246	DH2846	DH3046	DH3446	DH3846
DH18410	DH20410	DH24410	DH28410	DH30410	DH34410	DH38410
DH1852	DH2052	DH2452	DH2852	DH3052	DH3452	DH3852
DH1856	DH2056	DH2456	DH2856	DH3056	DH3456	DH3856
DH18510	DH20510	DH24510	DH28510	DH30510	DH34510	DH38510
DH1862	DH2062	DH2462	DH2862	DH3062	DH3462	DH3862
DH1866	DH2066	DH2466	DH2866	DH3066	DH3466	DH3866

16 1/2"	20 1/2"	24 1/2"	28 1/2"	32 1/2"	36 1/2"	40 1/2"
1'-8"	2'-0"	2'-4"	2'-8"	3'-0"	3'-4"	3'-8"
1'-9 5/16"	2'-1 5/16"	2'-5 9/16"	2'-9 5/16"	3'-1 5/16"	3'-5 9/16"	3'-9 5/16"
2'-0"	2'-4"	2'-8"	3'-0"	3'-4"	3'-8"	4'-0"
1'-10"	2'-2"	2'-6"	2'-10"	3'-2"	3'-6"	3'-10"

Primed Wood Double Hungs

Single Units (cont. on pg. 6)



# Double Hung Windows

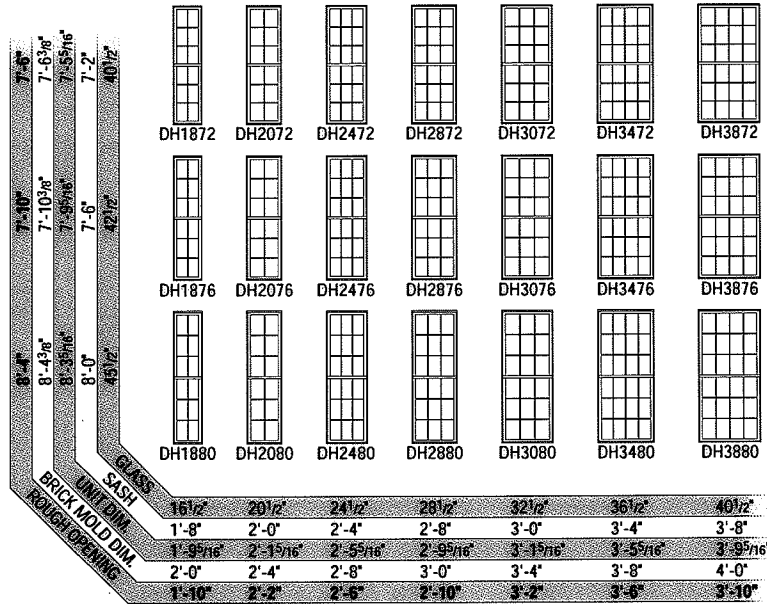

**Primed Wood Double Hungs**  
Single Units (cont. from pg. 5)

## FEATURES

- All sash are tilt-in and removable for easy cleaning
- Adjustable spring balance jamb liners
- Primed wood exteriors ready for paint or stain
- Standard 7/16 insulated glass manufactured to meet today's changing climates
- White or bronze hardware
- White or bronze screens available

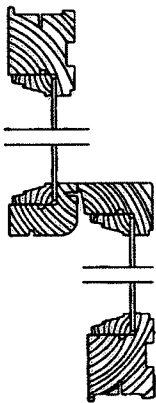

Single Glaze  
1 Lite

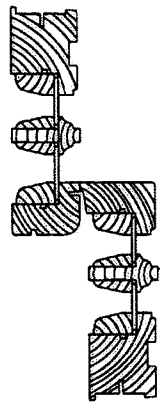

SSB/Narrow  
7/8" Bar

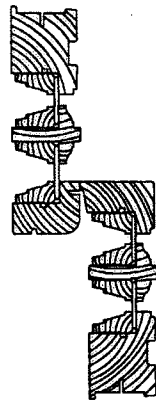

SSB/Wide  
1 1/4" TDL Bar

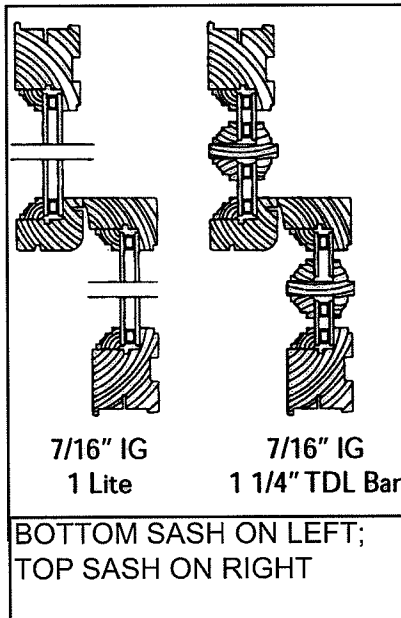

7/16" IG  
1 Lite

7/16" IG  
1 1/4" TDL Bar

BOTTOM SASH ON LEFT;  
TOP SASH ON RIGHT





# Double Hung Windows

Section Details  
4-9/16" Stucco Wall  
Not to Scale

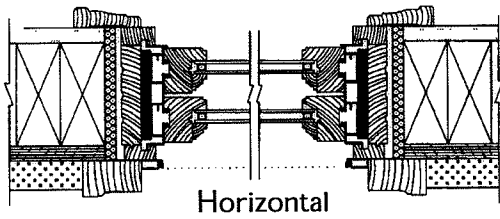
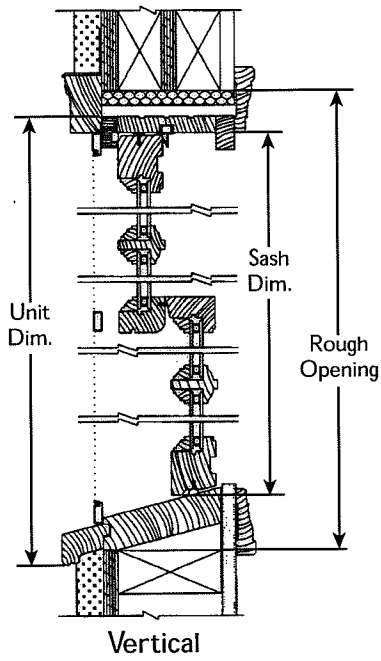

Section Details  
4-9/16" Wood Siding  
Not to Scale

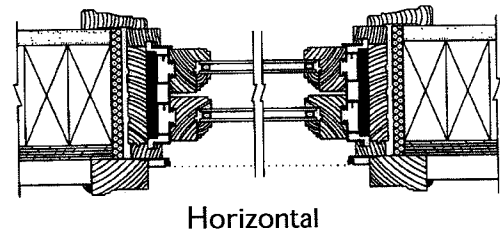
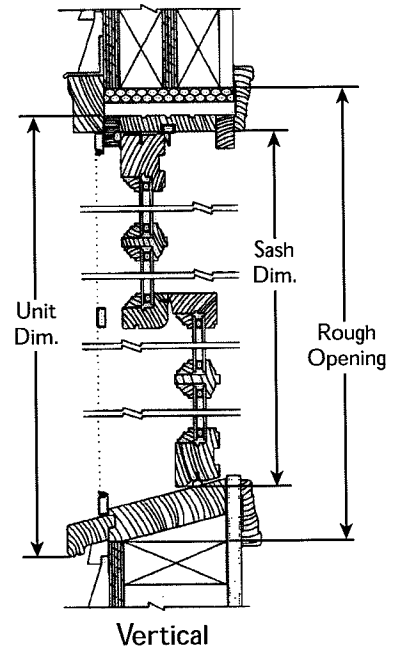

# Double Hung Windows

## FEATURES

- All sash are tilt-in and removable for easy cleaning
  - Adjustable spring balance jamb liners
- Primed wood exteriors ready for paint or stain
- Standard 7/16 insulated glass manufactured to meet today's changing climates
- White or bronze hardware
- White or bronze screens available

## OPTIONS

- Applied jamb extensions up to 7-1/2"
- White or bronze grills between glass
  - Single glazed true divided lights with historical 1-1/4" or 7/8" Mutin bars
  - Insulated true divided lights
- Grey or bronze tint, obscure, or tempered glass
- Wood screens available

Section Details  
4-9/16" Masonry Wall  
Not to Scale

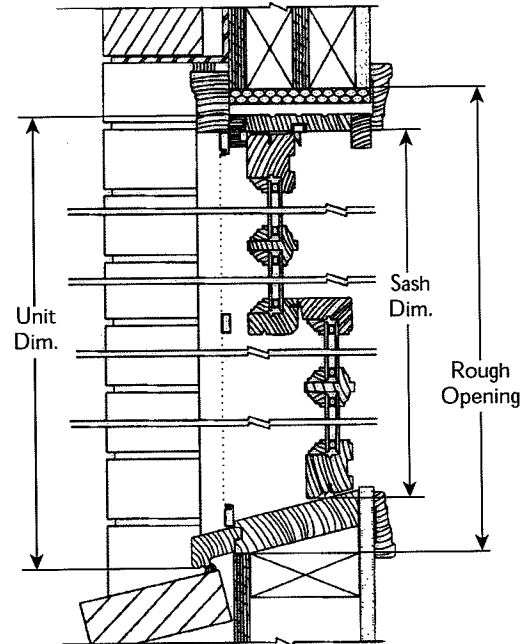

Vertical

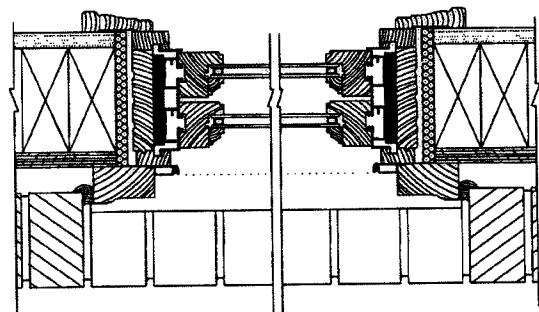

Horizontal



Historic District Commission Meeting

Sign In Sheet

12/5/2011

1

Mike Brinkley

2

Judy Ann Robinson

3

4

5

6

7

8

9

10

11

12

13

14

15

16

17

18

19

20